



LINKX PS100 SEMI-AUTOMATIC PACKING STATION

A semi-automatic packing station with case erecting and tape sealing applications



The NEW Linkx PS100 packing station is a cost effective packing solution ideal for small and medium sized businesses looking to increase production speeds.

The Linkx PS100 is semi-automatic machine that first erects cases and supports while being manually loaded. Each case is then pushed by the operator into extended side belts and folding mechanisms, then through bottom (and top if required) tape heads creating an accurately sealed and closed box every time ready for dispatch.



More information: T: +44 (0)1502 713777 E: info@linkxpackaging.com www.linkxpackaging.com

LINKX PS100 SEMI-AUTOMATIC PACKING STATION

A semi-automatic packing station with case erecting and tape sealing applications

The compact footprint of the Linkx PS100 makes it ideal for integration into existing factory and warehouse dispatch lines.

The machine can be manually adjusted by a side handle to suit varied case sizes and uses side belts to drive and accurately position cases, which are manually offered to the closing mechanisms by the operator giving them full control over the throughput of the machine. Raising the top tape unit allows the PS100 to be run as a semi-automatic case erector and supply erected and base sealed only cases for further processes. Based on the machines ease of use, operators need very little training to safely and efficiently use the machine.

Overall, the Linkx PS100 compact packing solution reduces labour whilst increasing efficiency, productivity and safety.

Features

- Power 230V, single phase
- Production speeds of up to 15/min
- K11 tape head (2")
- Simple machine adjustments
- Options for additional conveyors and casters

PS100 Box dimensions

Min. W. 150 H. 120 L. 150 mm

Max. W. 500 H. 500 L. ∞

PS100/4 Box dimensions

Min. W. 105 H. 90 L. 150 mm

Max. W. 500 H. 500 L. ∞

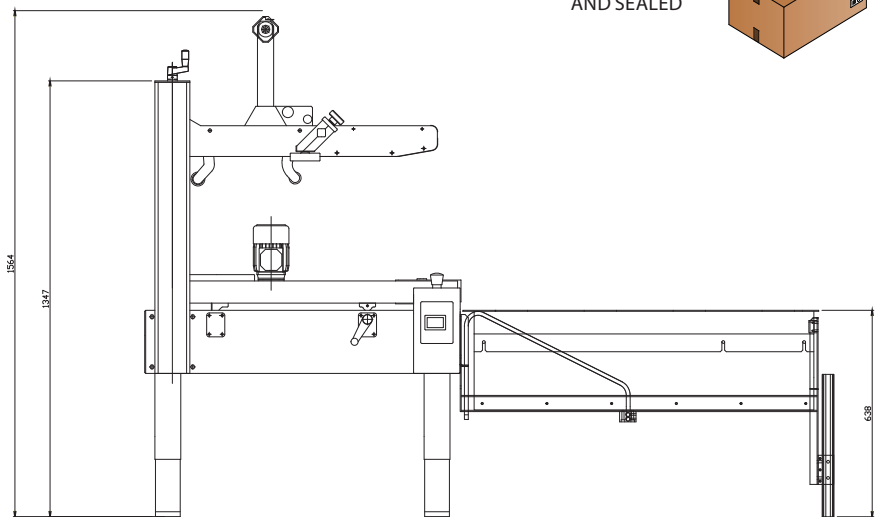
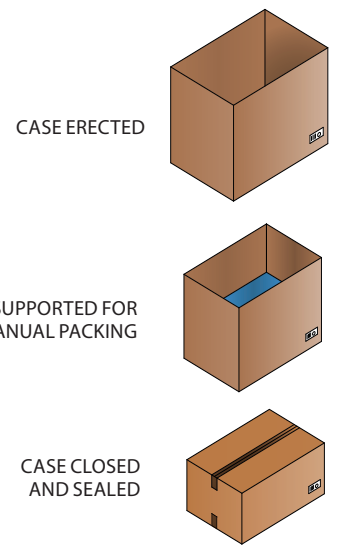

More information: T: +44 (0)1502 713777 E: info@linkxpackaging.com www.linkxpackaging.com