

Carton collators/loaders

CL120FTS | Scroll turner

Standard technical specifications

Speed: Up to 200 CPM*

Concept: Single size bottles (ovaloids or rounds)

Outfeed height: 900mm nominal

Sample power consumption: 3.24Kw, 14.09A/Ph, 440V, 3 Phase, N&E

Net weight: 550Kg

Specific components: Rockwell Controls, SMC Pneumatics

Colour: RAL 7035 grey

*Speed dependant on product and product format

Pack type

Glass or Plastic Containers

Options

Inline and right angle discharge

Changepart scrolls

Conveyors

Shrink wrapping

Automatic or robotic case/carton loading and closing

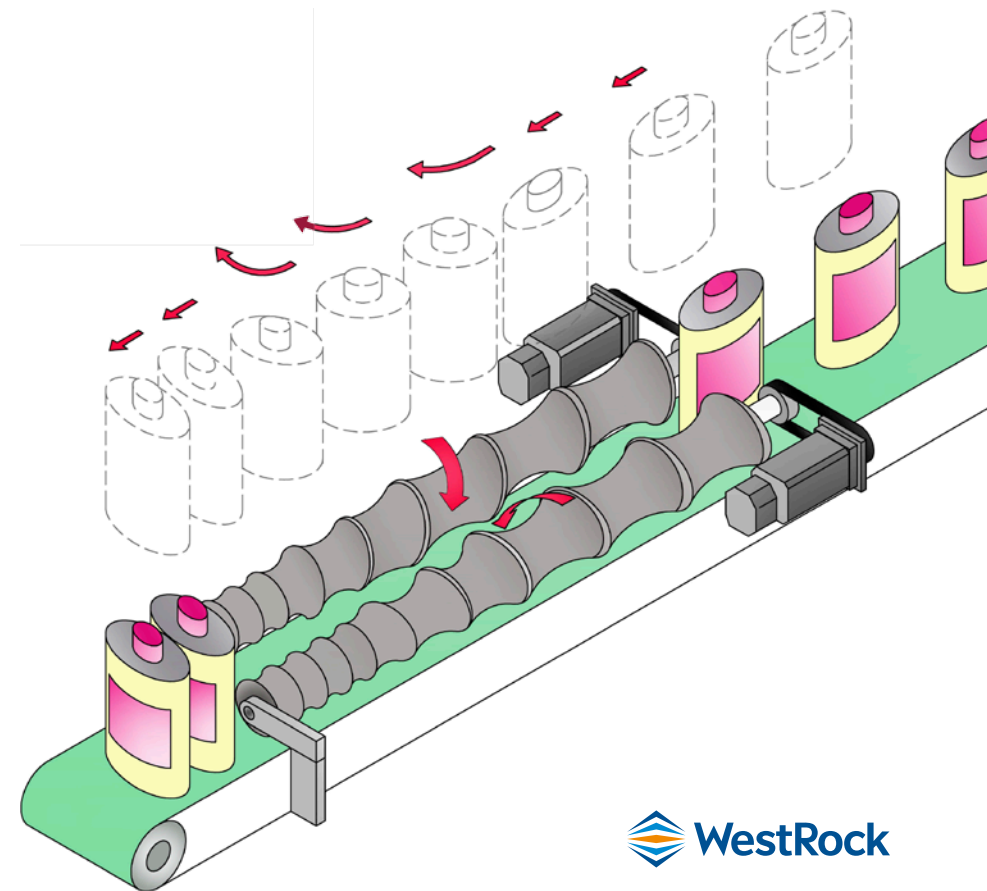

For more information, contact: WestRock Automated Packaging Systems
Phone: +44.0.1502.713777 • E-mail: aps.uk@westrock.com • www.linkxpackaging.com