

Carton collators/loaders

CL240SCU | Carton stacker collator

Standard technical specifications

Speed: Up to 200 CPM*

Concept: Multiple size

Infeed height: 1020mm

Outfeed height: 800-900mm nominal

Sample power consumption: 3.24Kw, 14.09A/Ph, 440V, 3 Phase, N&E

Air supply: Up to 8 cfm @ 80 psi (6 bar)

Net weight: 550Kg

Specific components: Rockwell Controls, SMC Pneumatics

Colour: RAL 7035 grey

*Speed dependant on product and product format

Pack type

Carton or Sachet

Options

Inline and right angle discharge

Conveyors

Shrink wrapping

Automatic or robotic case/carton loading and closing

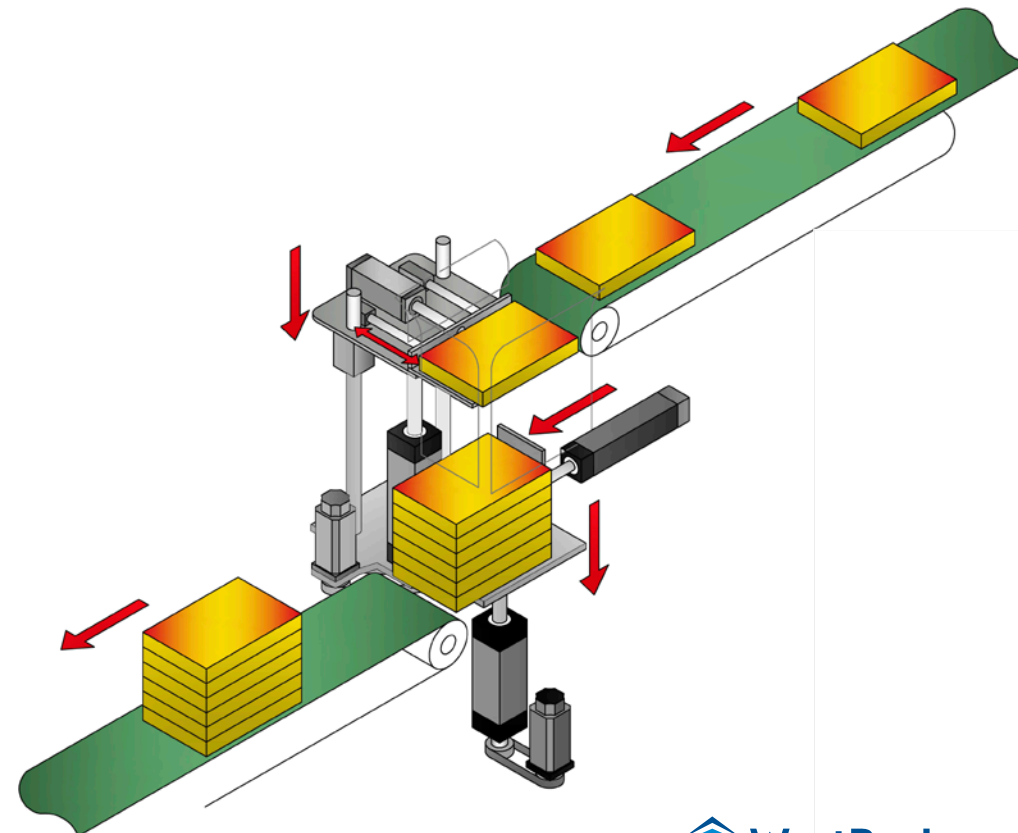

For more information, contact: WestRock Automated Packaging Systems
Phone: +44.0.1502.713777 • E-mail: aps.uk@westrock.com • www.linkxpackaging.com