

# Carton collators/loaders

## CL300SWH | Horizontal starwheel carton collator

### Standard technical specifications

**Speed:** Up to 300 CPM\*

**Concept:** Multiple size

**Infeed height:** To suit

**Outfeed height:** 900mm nominal

**Sample power consumption:** 3.24Kw, 14.09A/Ph, 440V, 3 Phase, N&E

**Net weight:** 550Kg

**Specific components:** Rockwell Controls

**Colour:** RAL 7035 grey

\*Speed dependant on product and product format

### Pack type

**Carton Styles:** End load or top load, glued

**Materials:** Carton board or corrugated

### Options

Inline and right angle discharge

Changepart starwheels

On demand multiple size tray forming

Conveyors

Shrink wrapping

Automatic case/carton loading and closing

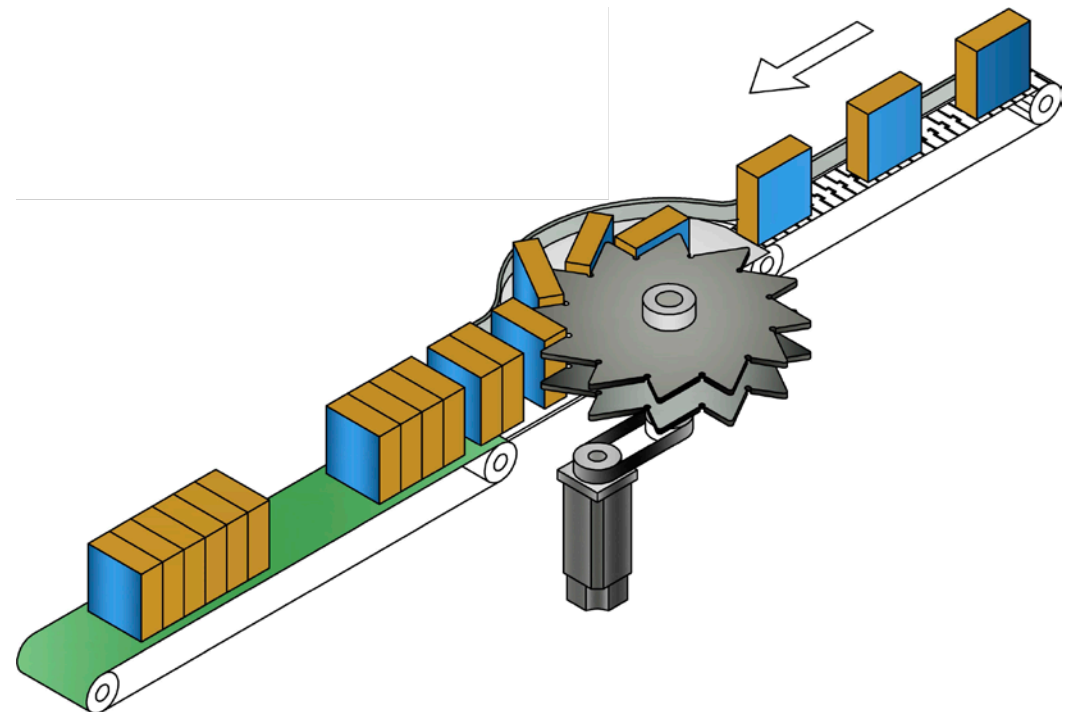

For more information, contact: WestRock Automated Packaging Systems  
Phone: +44.0.1502.713777 • E-mail: [aps.uk@westrock.com](mailto:aps.uk@westrock.com) • [www.linkxpackaging.com](http://www.linkxpackaging.com)