

CF Case/carton erectors

CFI-2000-G | Case/carton erector

Standard technical specifications

Speed: 8 to 25 CPM

Concept: Single size, simple adjustment between sizes

Board size: Min L200 x W150 x OH150 | Max L500 x W325 x OH520

Board magazine capacity: with 3mm B-flute - 200 blanks (1340mm)

Board magazine format: Inline feed 435mm to 540mm loading height

Outfeed height: 600mm +/- 30mm

Sample power consumption: 4.4Kw, 16A/Ph, 400V, 3 Phase, N&E

Air supply: Up to 15 cfm @ 80 psi (6 bar)

Net weight: 600Kg

Bottom closure: Hot melt glue

Specific components: Rockwell or Siemens Controls

Colour: RAL TBC

Board specification

Case/carton styles: FEFCO 0200, 0201 or HSC/RSC

Materials: B-flute, C-flute, E-flute or combination

Options

Speed variants from 8 to 25 cases per minute

FEFCO board style variants

Oversized and undersized case variants

Extended board magazine

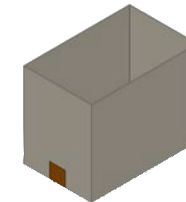

FEFCO 0200

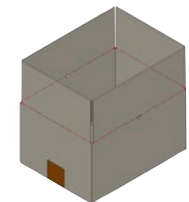

FEFCO 0201

- 1-Magazine
- 2-Suction frame
- 3-Flapfolder
- 4-Pusher arm
- 5-Sealing Section

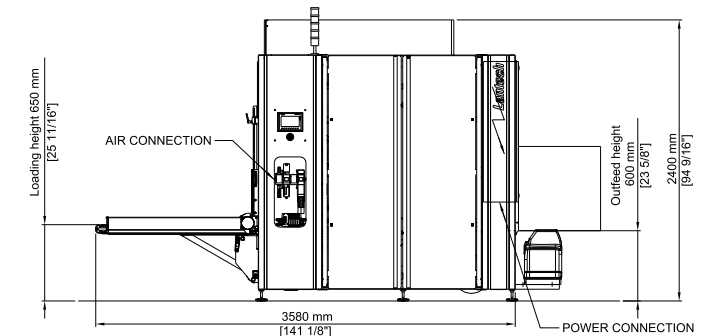
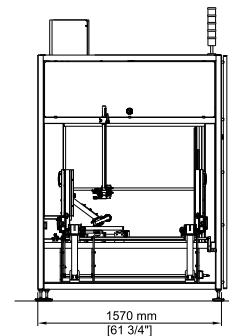
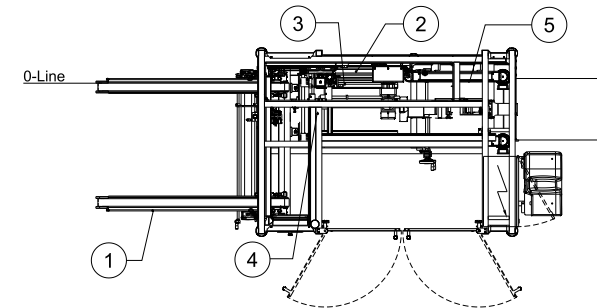

For more information, contact: WestRock Automated Packaging Systems
Phone: +44.0.1502.713777 • E-mail: aps.uk@westrock.com • www.linkxpackaging.com

